



Delaware Technology Student Association

2012 - 2013

MAGNETIC LEVITATION VEHICLES

Delaware Only Competition

*"SERVING TECHNOLOGY EDUCATION STUDENTS"
SPONSORED BY THE DEPARTMENT OF EDUCATION*

Draft 10/15/2012

MAGLEV VEHICLE RACE

Overview: Delaware TSA students entering the Maglev vehicle race are required to design and construct a vehicle which will levitate and balance over a 16 foot long magnetic track and will be moved down the track by a D. C. motor with a propeller. (The track sides are electrified by an 18-volt transformer.) Students will be judged on time trial results, originality of design and aesthetic value.

Written: Each student must submit a persuasive 1-2 page essay (roughly 5 paragraphs, 750 words) to the editor of a technical journal that compares and contrasts how maglev technology is a practical alternative to short-haul airlines. Include details on the technical specifications of how a maglev system works and add convincing reasons why adding a maglev system would be beneficial to the Mid Atlantic and Northeastern States.

Contest Purpose: To provide a means for TSA members to demonstrate their understanding of a practical application of magnetic levitation through the design and construction of an original Maglev vehicle within a set of track/vehicle specifications. The contest rules and specifications will be based on the Maglev competition guidelines (attached).

Eligibility for Entry: One Maglev Vehicle per individual student.

Levels of Competition: Level I and Level II.

Time Limitations: Home School Preparation - vehicle must be submitted during event registration.

Specific Regulations:

- a. Vehicle shall be suspended solely by means of magnetic levitation. Conductive wires may not rest on the top or the rails.
- b. Vehicles must be at least 1.5" tall and 12" or less in length.
- c. There is no maximum height, nor minimum length restrictions.
- d. The magnetic polarity must be compatible with track specifications.
There is no limit to the number of magnets which may be affixed to a vehicle.
- e. Students will be allowed to adjust and place magnets to track magnets at competition site prior to initial track competition.
- f. The track will be 16 feet long (14 ft race length) and powered by a 12 to 18 volt transformer. See included diagram for track specifications.
- g. Vehicle must be powered by one DC motor as available from such vendors as Kelvin, Pitsco, Radio Shack, etc... and one propeller (Example is a **Kelvin #850647 3-6v 17,000 rpm motor**). Power must come completely from the electrified track.
- h. Once competition begins, after testing phase is over, no repairs and/or modifications can be made. If a vehicle becomes inoperative, it will be eliminated from competition.
- i. Body material is to be supplied by contestant. Choice of material is the option of the contestant.
- j. **Schools must provide all materials including motors and propellers for competition.**
No on-site construction is allowed; however, modifications and adjustments can be made prior to on-track competition.
- k. Students must wear eye protection during the adjustment, testing, and competition periods.

Resources:

Each entry must supply all of the necessary parts/tools/supplies to make repairs and/or adjustments on site; before competition begins. **No tools will be provided by DETSA on site.** Tables to work on will be at the site.

Procedure:

- a. Students will work individually to construct and design a maglev vehicle.
- b. The Maglev will then be judged on originality, appearance, design specification and race time.
- c. Students must be present when racing the vehicle.
- d. Students will have time to arrange and affix their magnets according to the track's polarity before racing.
- e. Students will have three race attempts - if vehicle is not able to run, it will be rated as "Did not finish."
- f. Written: Students must submit the *persuasive 1-2 page essay on March 23, 2013.*

Criteria for Judging:

- a. Originality, design, and appearance **25 pts.**
- b. Race times **50 pts.**
 - 1st - 50 pts.**
 - 2nd - 45 pts.**
 - 3rd - 35 pts.**
 - 4th - 30 pts.**
 - 5th - etc.**
- c. Written Report **25 pts.**

TOTAL 100 pts.

Delaware MAGLEV Track Specifications

Side View

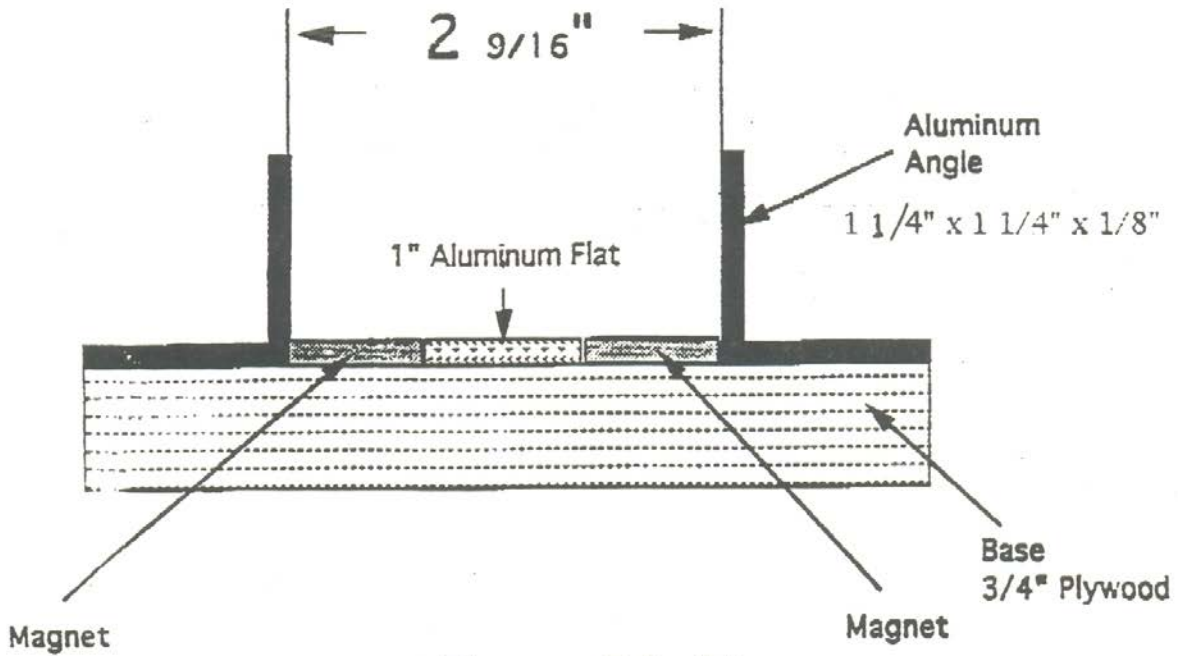

Diagram 5.4 - 2.1

Top View

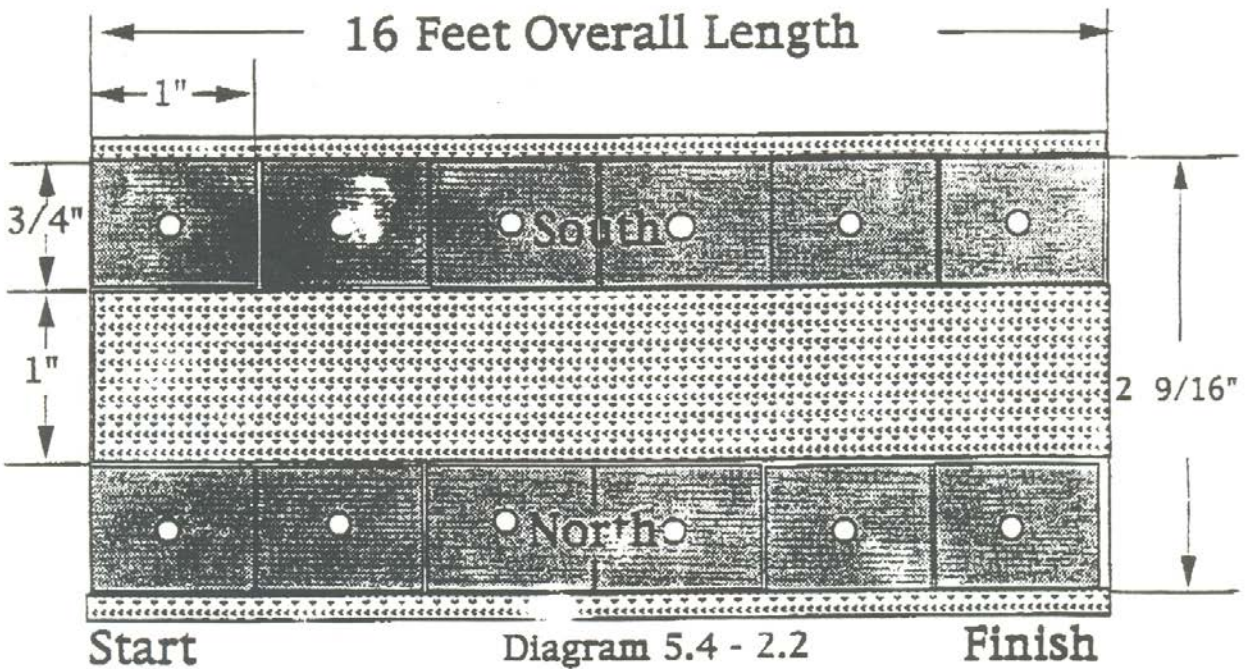

Diagram 5.4 - 2.2

DELAWARE TSA STATE CONFERENCE
Competitive Event Evaluation

MAGLEV VEHICLE RACE

Student's ID: _____ Level: _____

Chapter/School No. _____

A. _____ ORIGINALITY, DESIGN, & APPEARANCE (25 pts)

- _____ Design meets all vehicle specifications **10 pts.**
- _____ Originality of vehicle design **10 pts.**
- _____ Overall design appearance & aesthetic value **5 pts.**

B. _____ RACE TIME TRIAL RESULTS (50 pts)

1st = 50 pts. 2nd = 45 pts. 3rd = 35 pts. 4th = 30 pts. 5th = 25 pts.
*If vehicle travels the distance but does not make top five times = 10 to 20 pts.
*Did not finish = DNF (0 pts)

_____	_____	_____	_____	_____
<i>1st time trial</i>	<i>2nd time trial</i>	<i>3rd time trial</i>	<i>Average time</i>	<i>Rank</i>

C. _____ WRITTEN (25 pts.)

- _____ Masterful Response..... **21-25 pts.**
- _____ Skilled Response..... **16-20 pts.**
- _____ Satisfactory Response..... **10-15 pts.**
- _____ Insufficient Response..... **0-9 pts.**
- _____ No Response **0 pts.**

D. _____ RULES VIOLATION (-20 pts.)

_____ **POINT TOTAL**

_____ **RANKING**

Judge's Signature _____

	Description
Masterful Response	<ul style="list-style-type: none"> • <i>Illustrates a thorough understanding of the persuasive task with a consistent focus on the topic through outstanding control over and development of ideas [details, reasons, examples, evidence, anecdotes, events, descriptions, etc.]</i> • <i>Presents an effective organization through the use of purposeful paragraphs, including a compelling introduction, purposeful transitions between paragraphs, and an effective conclusion.</i> • <i>Establishes a consistent perspective or stance with distinctive tone and style appropriate for purpose and audience.</i> • <i>Demonstrates consistent use of appropriate, powerful, precise language to support development of ideas.</i> • <i>Contains only few errors, illustrating effective control of age-appropriate standard writing conventions [spelling, usage, punctuation, and capitalization] that are correct to the extent that errors do not detract from overall delivery and requires only minimal editing.</i>
Skilled Response	<ul style="list-style-type: none"> • <i>Illustrates a competent understanding of the persuasive task with a clear focus on the central topic through strong control over and development of ideas [details, reasons, examples, evidence, anecdotes, events, descriptions, etc.] that usually, but not always, are relevant to and add support for the central topic with minimal or no digression.</i> • <i>Presents a planned organization through the use of multiple paragraphs, including an effective introduction, useful transitions between paragraphs, connections between ideas that may be predictable, and a conclusion that provides a sense of resolution.</i> • <i>Establishes a clear perspective or stance with a tone and style appropriate for purpose and audience.</i> • <i>Exhibits variety in sentence structure and length to ensure the smooth flow of ideas throughout most of the response.</i> • <i>Demonstrates use of appropriate language throughout most of the response to support development of ideas.</i> • <i>Contains occasional errors, illustrating reasonable control of age-appropriate standard writing conventions [spelling, usage, punctuation, and capitalization] that are correct to the extent that errors detract only minimally from overall delivery and requires only minor editing.</i>
Satisfactory Response	<ul style="list-style-type: none"> • <i>Illustrates a satisfactory understanding of the persuasive task with a focus on the central topic through adequate development of ideas [details, reasons, examples, evidence, anecdotes, events, descriptions, etc.] that somewhat support the central topic but may be undeveloped and/or sometimes list-like.</i> • <i>Presents an organization that loosely supports the central topic, with or without multiple paragraphs includes few transitions between paragraphs; ends with a conclusion that is predictable or may be a restatement of the introduction.</i> • <i>Attempts to establish a perspective or stance but presents an uneven tone and style that are minimally adequate for purpose and audience.</i> • <i>Exhibits minimal variety in sentence structure and length and may include sentences that are mechanical and/or rambling but understandable.</i> • <i>Contains errors, illustrating limited control of age-appropriate standard writing conventions [spelling, usage, punctuation, and capitalization] to the extent that errors may detract from overall delivery and require moderate editing.</i>
Insufficient Response	<ul style="list-style-type: none"> • <i>Illustrates little or no understanding of the persuasive task with only a weakly implied focus or no focus on the central topic with no control over development of ideas [details, reasons, examples, evidence, anecdotes, events, descriptions, etc.] that relate to the central topic and are confusing, illogical, or undeveloped.</i> • <i>Lacks organization to support the central topic with or without multiple paragraphs; may include an introduction that provides little or no direction may or may not end with a conclusion, which, if present, is often inappropriate and/or unconnected.</i> • <i>Demonstrates little or no perspective or stance; shows little discernable tone or style or may show inappropriate tone or style.</i> • <i>Includes some sentences with structural and word placement problems, a pattern of simple and monotonous sentences that may be unclear.</i> • <i>Uses some vague or incorrect language that may be confusing; contains words and expressions that may be redundant, vague, or incorrect.</i> • <i>Contains numerous errors, illustrating a struggle with control of age-appropriate standard writing conventions [spelling, usage, punctuation, and capitalization] to the extent that errors detract from overall delivery and require extensive editing.</i>